



# CLS-E NG YOKE.

**Your entry point into realistic Flight Experiences - feel the difference.**

The BRUNNER CLS-E NG Yoke is the consequent evolution of our long-term success product CLS-E Yoke, incorporating all gained experience and many customer voices, asking for an affordable, reliable and realistic flight experience.

The CLS-E NG Yoke integrates perfectly into many ambitious enthusiast applications, but also into new or existing cockpit training environments. CLS-E NG Yoke provides excellent quality, high fidelity and unique durability at an affordable entry-level cost. It is unmatched in its class: intelligent brushless DC motor technology, a compact and sophisticated product design including Beechcraft style yoke handle creates training solutions which provide optimum training value.

The BRUNNER CLS-E NG Yoke is supporting single as well as dual pilot applications. A unique real-time yoke synchronization logic enables unmatched and automatic pilot/co-pilot take-over functionality. On Top, CLS-E NG simulates and represents various functions like autopilot and trim and allows for easy and fast installation and setup through real Plug- and Play capability. Enabled by our CLS2Sim software-environment, the CLS-E NG Yoke communicates easily with commercially available simulation software such as X-Plane, MS-FSX, Microsoft FS2020, and Prepar3D®. Any third party flight simulation solution connects via a simple TCP/IP or UDP remote interface protocol.



# CLS-E NG YOKE.

## Features.

- BRUNNER Drop-In or Desktop: fully integrated, with build-in control unit and 24 VDC power inlet (ext. power supply included)
- High fidelity for most realistic flight experience
- Including Beechcraft style yoke wheel with 5 programmable functions and 8 direction Hat Switch
- Simulated effects: engine, ground, turbulence, real trim, autopilot, stall etc.
- Dynamic pressure dependent force profile
- Brunner real-time synchronization logic for dual-pilot cockpit with automatic pilot/co-pilot take-over (MCC)
- Designed for cockpit environment or desk-top application
- Plug & Play (USB and CAN)
- Reliable, smooth and maintenance free design
- No fan, very quiet, high efficient
- Contactless high-resolution position feedback
- Direct support for X-Plane, MS-FSX, FSX Steam Edition, Microsoft FS2020 and Prepar3D® with Brunner CLS2SIM SW, X-Plane plugin for Windows, Linux and Mac
- CLS2Sim license for private / no commercial use included
- Swiss Made
- 2 Years warranty

## Specification.

<b>Peak Force</b>	Pitch: 40 N / 9 lb-ft Roll: 1.7 Nm / 1.3 lb-ft	<b>Interface</b>	USB (USB-2 Type B) CAN (RJ45)
<b>Travel</b>	Pitch: 90 mm / 3.6 in Roll: +/- 90°	<b>Power</b>	120W peak (no fan)
<b>Yoke handle</b>	BRUNNER Beechcraft style optional: delivery without handle	<b>Operating Voltage</b>	19 - 24 VDC
		<b>Size</b>	340 x 230 x 90 mm 13.38 x 9 x 3.54 in
		<b>Weight</b>	5 kg / 11 lb

## Dimensions.

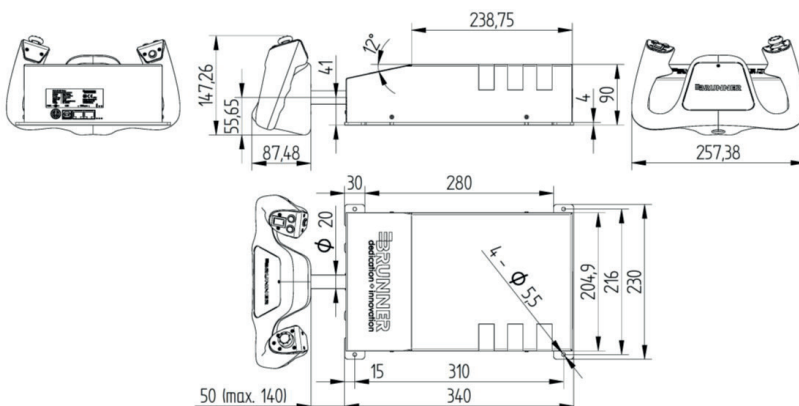

CANopen®

